



INSTALLATION GUIDE

800 SERIES DRAWER SYSTEMS



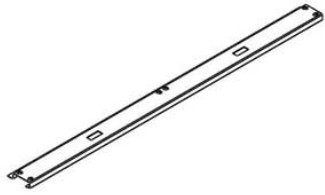

FIG 1
1x Front Rail

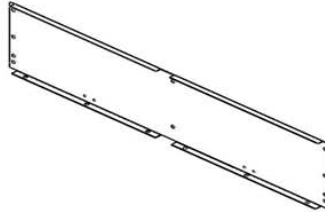

FIG 2
1x Back Panel

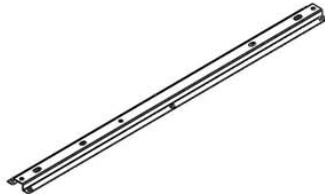

FIG 3
x1 1 Piece Floating Rib (1PFR)
x1 2 Piece Floating Rib (2PFR)



FIG 4
1x Back Rail (BR)

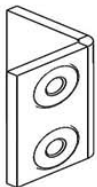

FIG 5
4x Drawer Stoppers

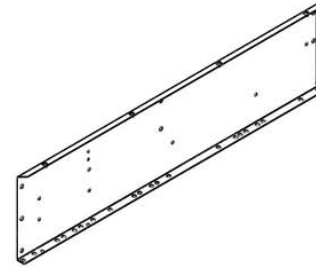

FIG 6
1x Left Hand Panel

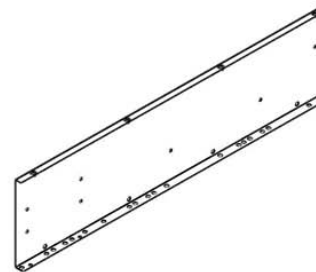

FIG 7
1x Middle Panel

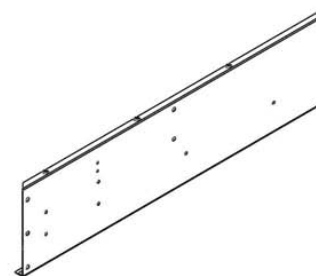

FIG 8
1x Right Hand Panel

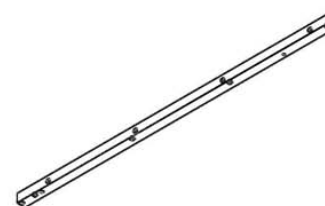

FIG 9
2x Support Brackets

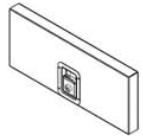

FIG 10
2x Drawer Fronts



FIG 11
4x Drawer Ends

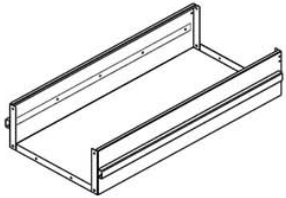

FIG 12
2x Drawer Bodies

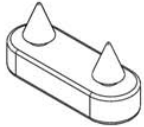

FIG 13
2x Rubber Drawer Stops

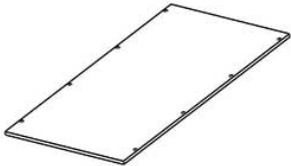

FIG 14
2x Wooden Carpeted Tops



FIG 15
1x Aluminium Front Trim

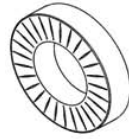

FIG 16
36x 8mm Washers



FIG 17
36x 8mm Bearings



FIG 18
29x 8mm Star Washers

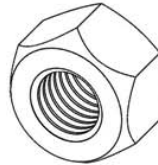

FIG 19
29x 8mm Nylon Nuts



FIG 20
22x M8 x 25mm Bolts



FIG 21
7x M8 x 35mm Bolts



FIG 22
6x 8g x 10mm Screws



FIG 23
12x M6 x 10mm CSK Screws



FIG 24
62x M6 x 16mm CSK Screws

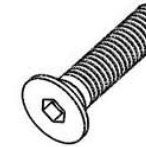

FIG 25
16x M6 x 25mm CSK
s/s Socket Head Screws



FIG 26
8x M6 x 16mm Pan Head Screws



FIG 27
12x 6mm Nylon Nuts



STEP 1

Attach left and right hand panels to front and back rails as shown using M6 x 16mm CSK (FIG 24) Screws in eight (8) places.

NOTE: Position back rail with extra screw holes to outside of frame (Diagram 1).

Position back rail with extra screw holes to outside of frame.

The others are for the rear panel.

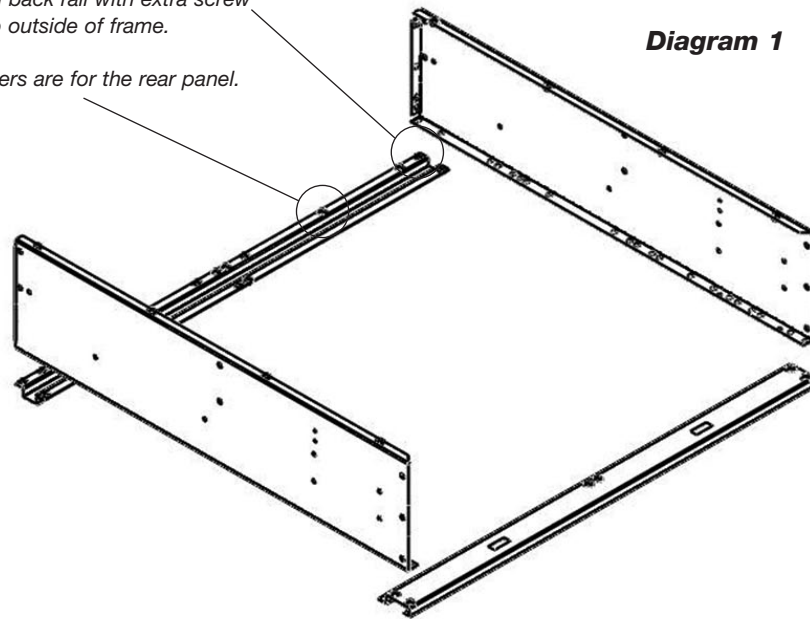
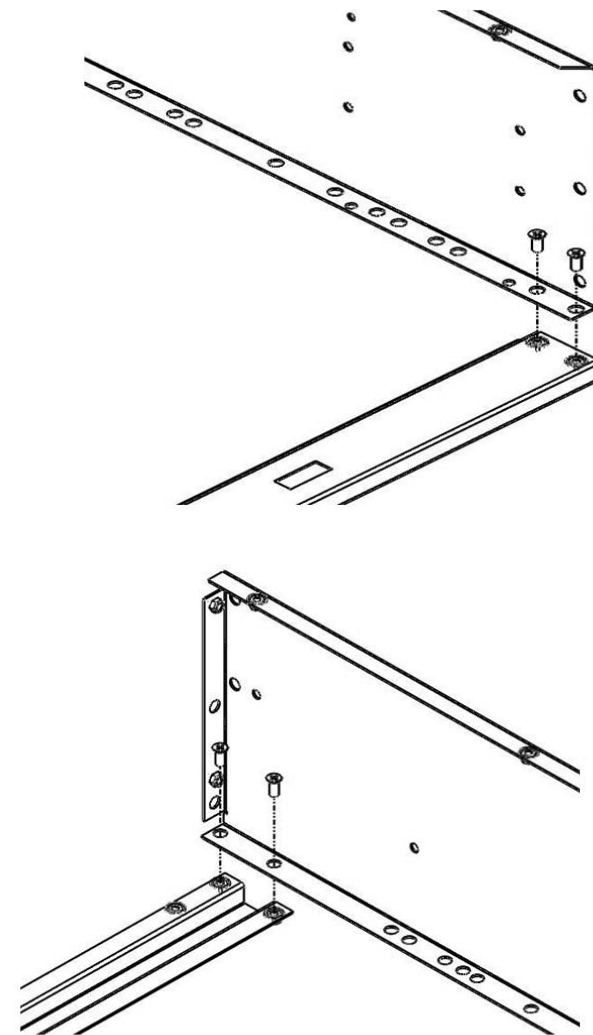
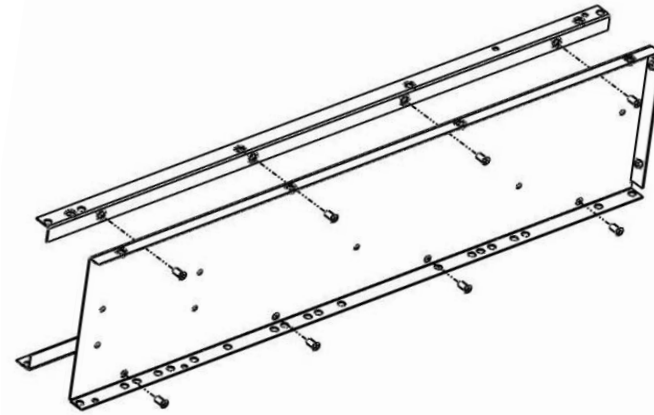

Diagram 1



STEP 2

Attach support brackets to middle panel top and bottom as shown below using M6 x 16mm CSK (FIG 24) screws in eight (8) places.



STEP 3

Attach middle panel to frame as shown below (Diagrams 2 & 3) using M6 x 16mm CSK (FIG 24) screws in six (6) places.

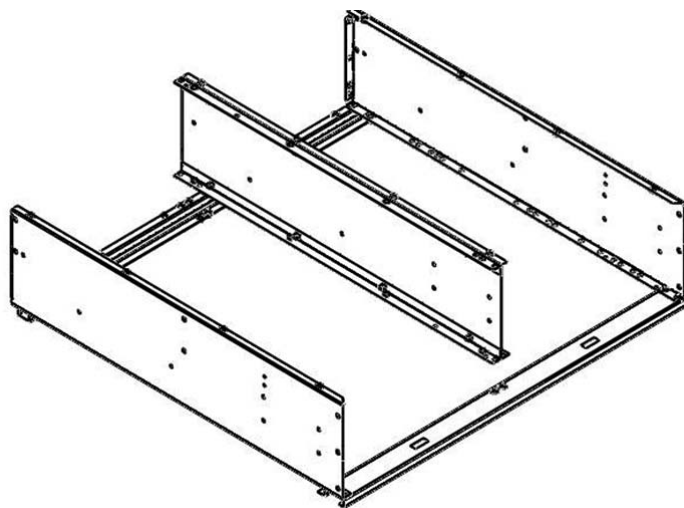

Diagram 2

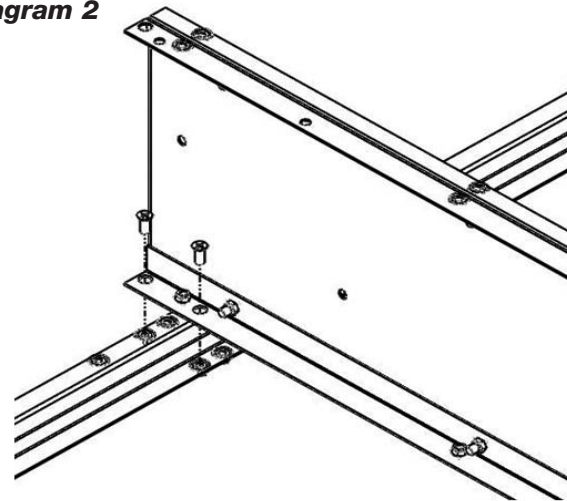
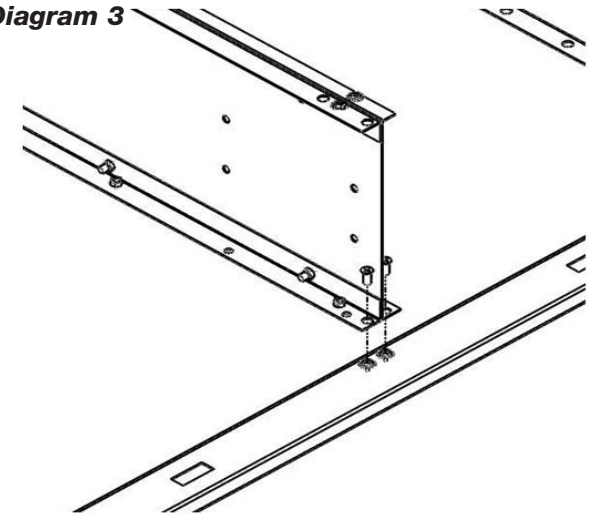
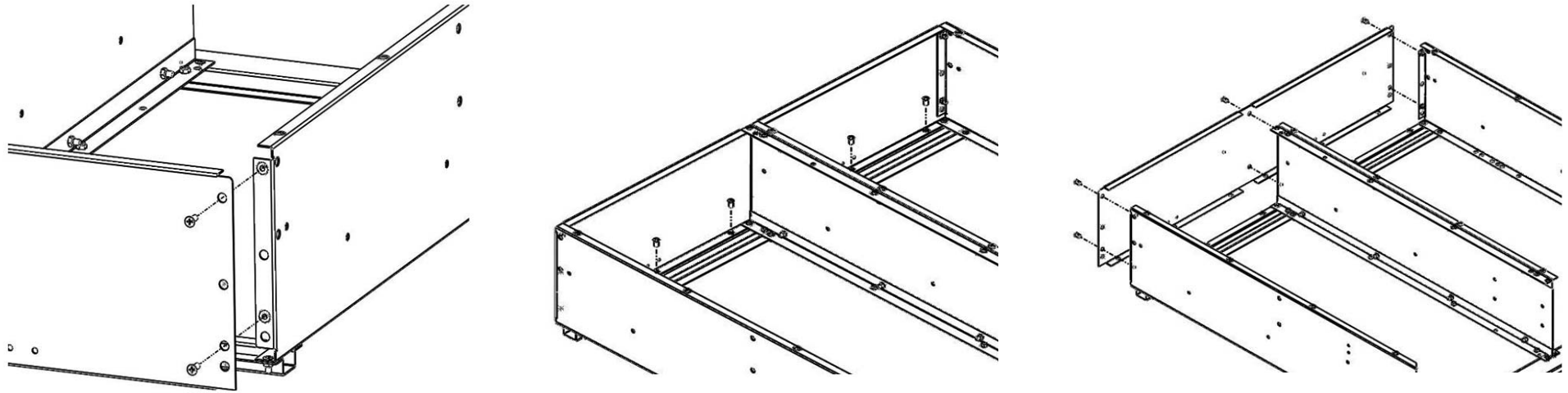

Diagram 3



STEP 4

Attach back panel to frame as shown using M6 x 16mm CSK (FIG 24) screws in twelve (12) places.



STEP 5

Attach Rubber Drawer Stops through 6.5mm holes in back panel in two places by pushing arrow head points into holes (Diagram 1) and pulling through gently as not to tear them and so they clip in as shown.

Diagram 1

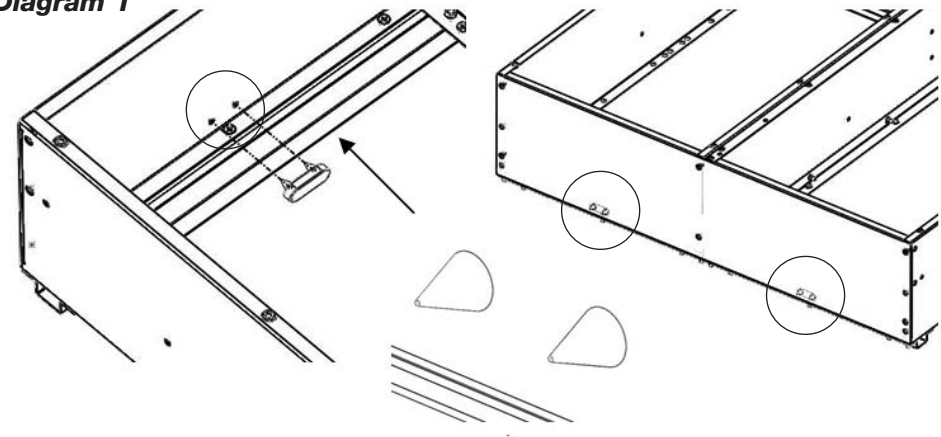

STEP 6

Attach Floating Ribs x 2 to frame as shown using M6 x 16mm CSK (FIG 24) screws in twelve (12) places.

NOTE: Refer to Model Specific spec sheets for Floating Rib locations.

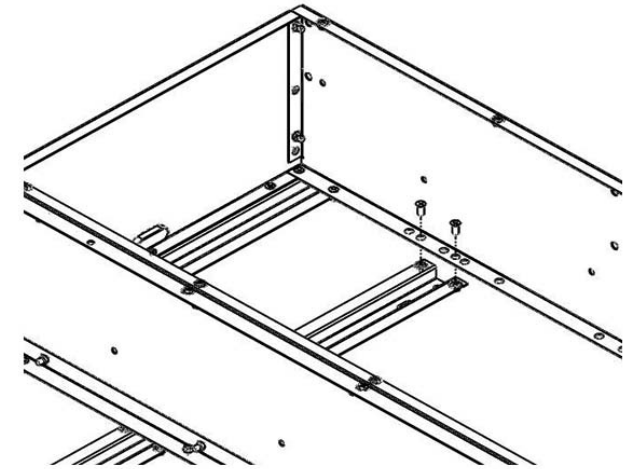
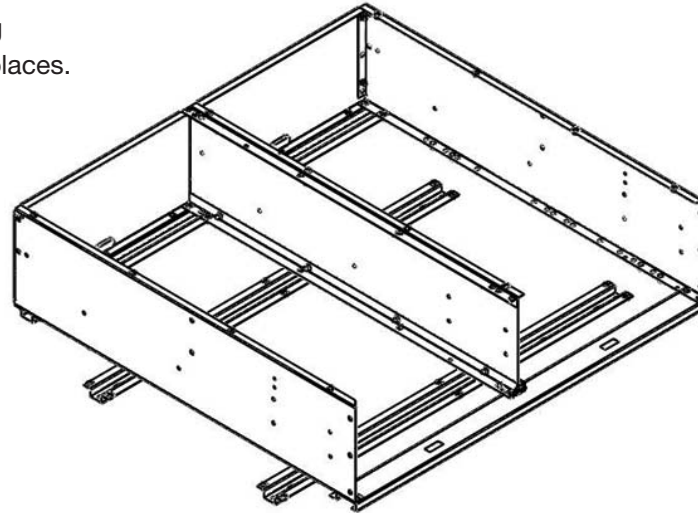

STEP 7

Attach Drawer Stopper brackets to left and right hand panels as shown using M6 x 16mm Pan Head (FIG 26) screws in four (4) places.

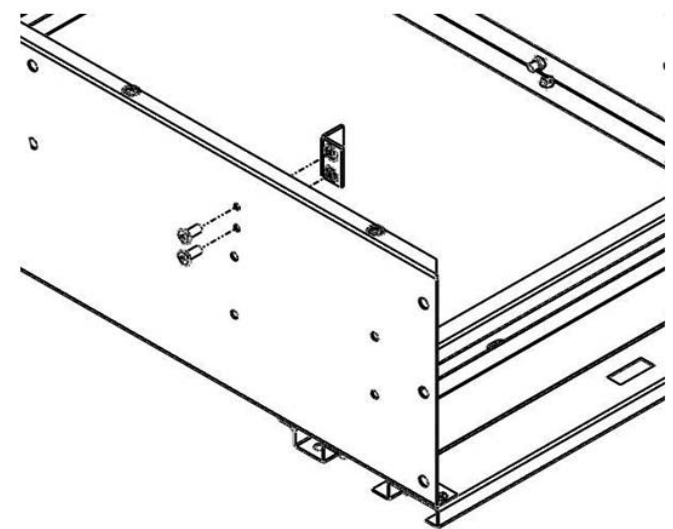
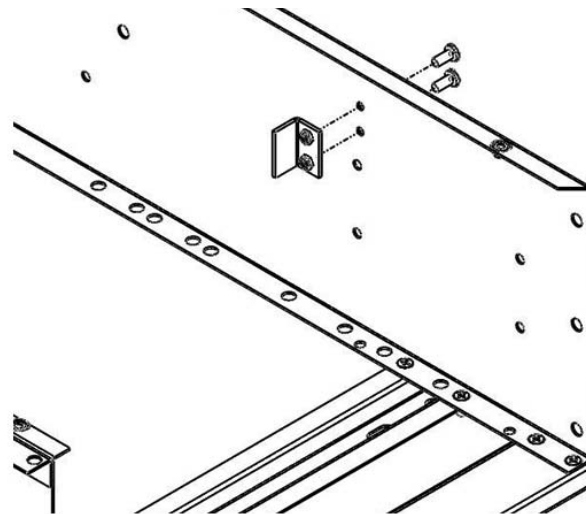

STEP 8

Install bearings to left and right panels as shown using M8 x 25mm Bolt (FIG 20), 8mm Washer (FIG 16), Star Washer, Bearing (FIG 17) and 8mm Nyloc Nut (FIG 19) as per configuration shown in fourteen (14) places.

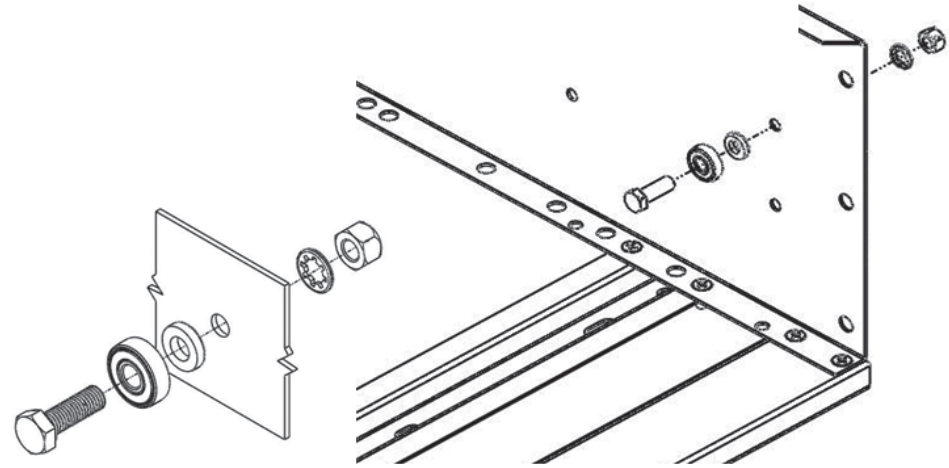

STEP 9

Install bearings to 8mm holes in all bottom flanges of frame as shown (Diagram 1) using M8 x 25mm Bolts (FIG 20), 8mm Washer (FIG 16), Star Washer, Bearing (FIG 17) and 8mm Nyloc Nut (FIG 19) as per configuration shown below in eight (8) places.

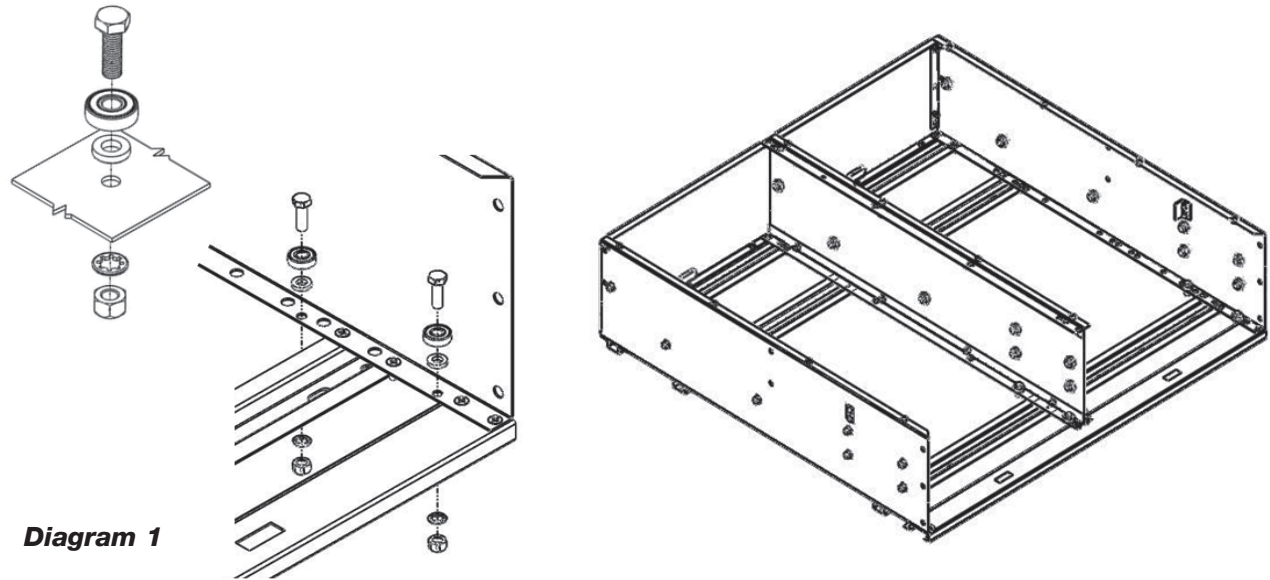
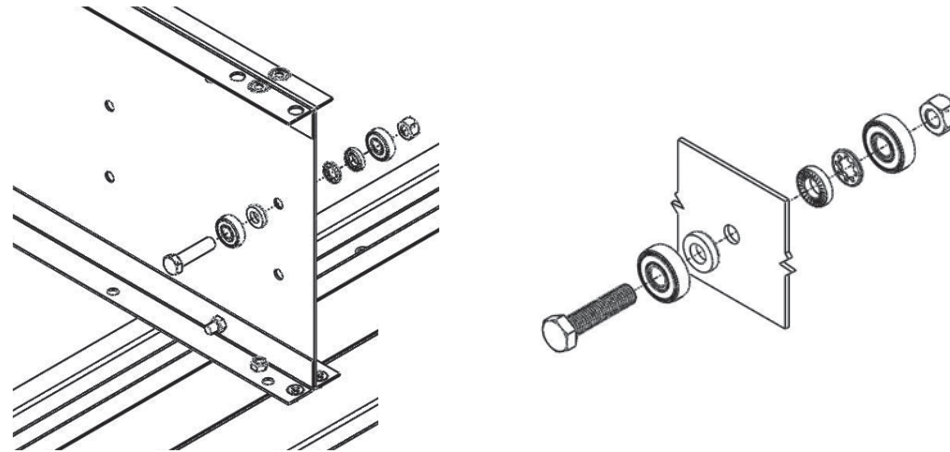

Diagram 1



STEP 10

Install bearings to middle panel as shown using M8 x 35mm Bolt (FIG 21), 8mm Washer (FIG 16), Star Washer, Bearing (FIG 17) and 8mm Nyloc Nut (FIG 19) as per configuration shown below in seven (7) places.



STEP 11

Assemble drawers by installing drawer ends into draw carcass.

NOTE: Ensure folded lip on drawer end faces outside of drawer carcass.

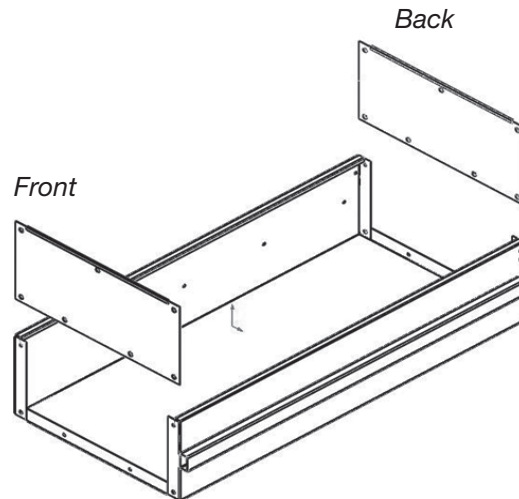

STEP 12

Attach rear drawer end to carcass using M6 x 10mm CSK (FIG 23) screws as shown in six (6) places on each draw.

NOTE: To determine back and front of drawer carcass - look for the 6.5mm holes on the sides of drawer. They are towards the **BACK** of the drawer.

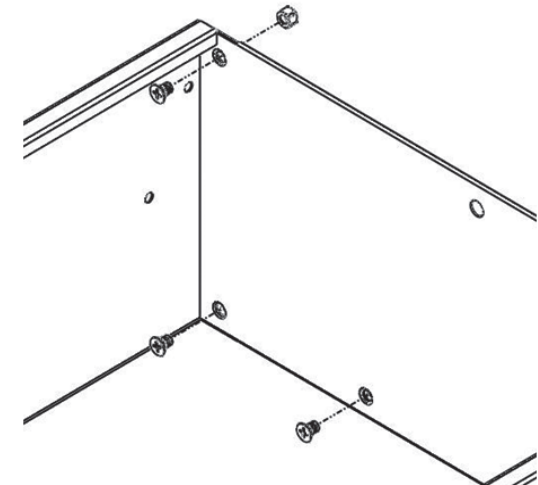

STEP 13

Attach drawer fronts to front of carcass using M6 x 16mm CSK (FIG 24) screws as shown (Diagram 1) in seven (7) places on each drawer.

NOTE: These same screws also attach the drawer end to the drawer carcass so make sure drawer end is in place first and screws go through both as shown.

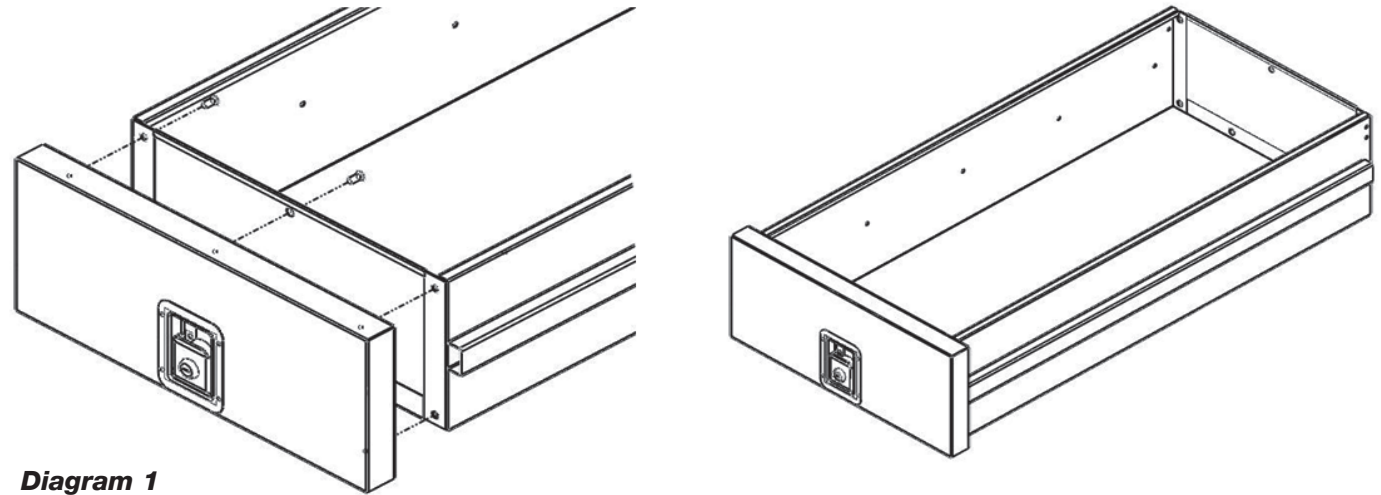
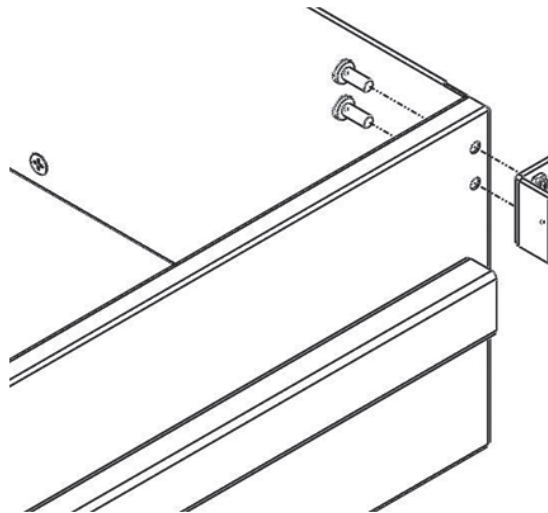

Diagram 1

STEP 14

Insert drawer assembly into frame.



IMPORTANT: IT IS RECOMMENDED TO INSTALL FRAME INTO VEHICLE BEFORE COMPLETING THIS STEP FOR EASE OF INSTALLATION. PLEASE REFER TO PAGES 12-16 FOR YOUR VEHICLE SPECIFIC INFORMATION.

STEP 15

Install Drawer Stoppers to outside of draws using M6 x 16mm Pan Head (FIG 26) screws as shown in two (2) places on each drawer.

NOTE: Ensure drawer is pushed in far enough so that upon installing stoppers they are behind the stoppers already attached to frame. (Drawer missing from diagram).

Also ensure stoppers are attached opposite each other as shown.

NOTE: This image may confuse as the drawer stop is pictured but the drawer is missing from diagram. The idea is to show how the assembly works and how it looks in situ. So imagine this drawer stop bracket is on the drawer.

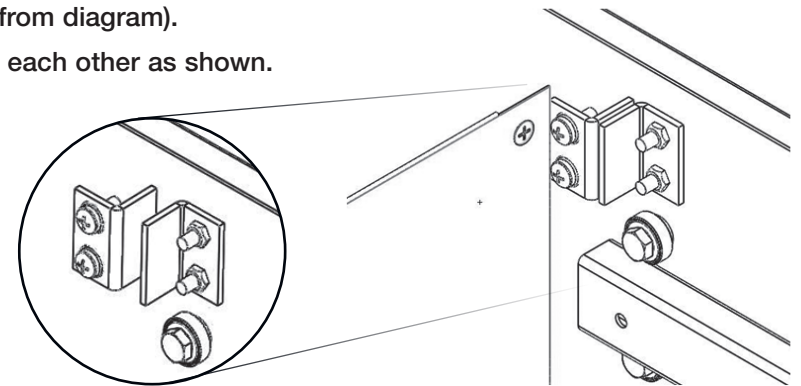

STEP 16

Attach Wooden Carpeted (FIG 14) to top of flanges of frame as shown using M6 x 25mm S/S Socket Head (FIG 25) screws in 16 places.

NOTE: These same screws also attach the drawer end to the drawer carcass so make sure drawer end is in place first and screws go through both as shown.

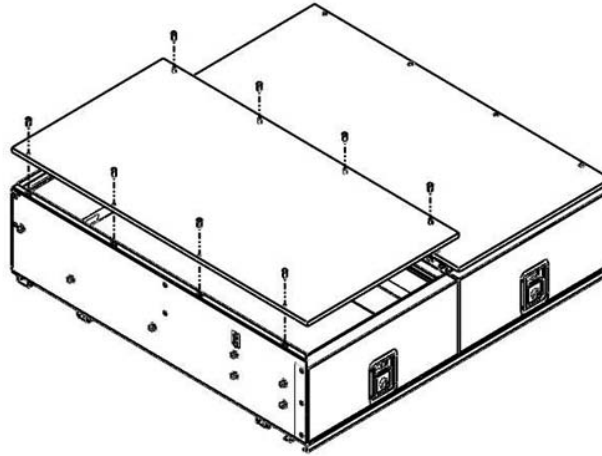

COMPLETED

Your finished product should represent this picture.

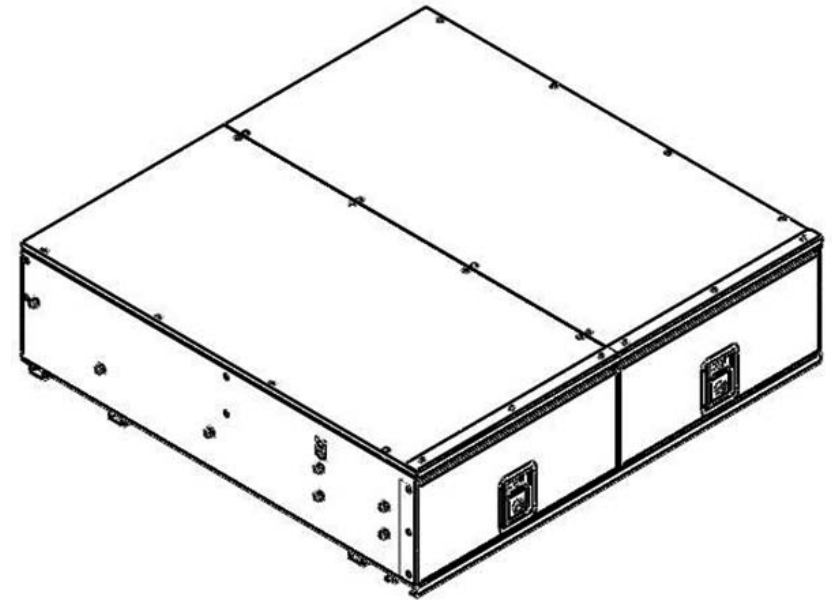

STEP 17

Attach aluminium front trim to front edge of carpeted boards as shown using 8g x 10mm (FIG 22) screws.

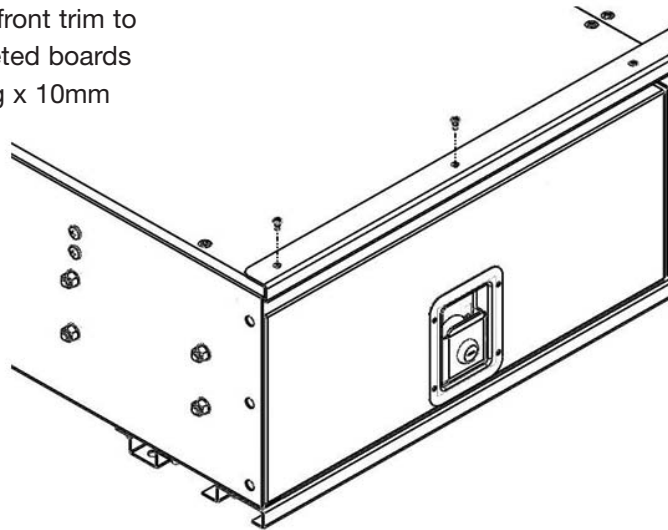

Hardware Listing

WASHERS	PACKERS	BOLTS	NUTS
4 x M10 x 25mm	4 x 20mm	4 x M10 x 35mm	4 x M10 Nyloc
2 x M6		2 x M6 x 35mm	
4 x Mudguard			

NOTE: As this system is made to suit multiple vehicles, you will have some hardware left over.

Floating Rib Installation

1. Identify your vehicle information in the Vehicle Mounting Ribs Measurements table. You have by this stage assembled the frame and are now ready to install the specific locations of the floating ribs (1PFR and 2PFR) to the frame to suit your vehicle.
2. You will notice along the inside bottom flange of all bearing panels there are various holes punched, this is where you need to fix the floating ribs in the positions you will get from the Matrix. There are two floating ribs with two different mounting positions. Refer to Diagram 1. Some vehicles may only require 1 floating rib as the front or back rail may be used.
3. Most vehicles will have standard width floating ribs, in some rare cases such as a Pajero. In this case the floating rib needs to be longer and therefore is supplied as a two piece. This is to accommodate vehicle fixing mounts that are outside the drawer system's width, the fixings to the frame remain the same as the positions used in the Matrix. Refer to Page 14 for installation diagram.
4. The position measurement (A & B) is taken from the front edge of the lock rail to the rear edge of the floating rib.
5. Your required fixing position of the floating ribs will line up with existing holes.
6. Use M6 x 16mm Pan Head screws provided to mount the floating ribs to frame.

Diagram 1

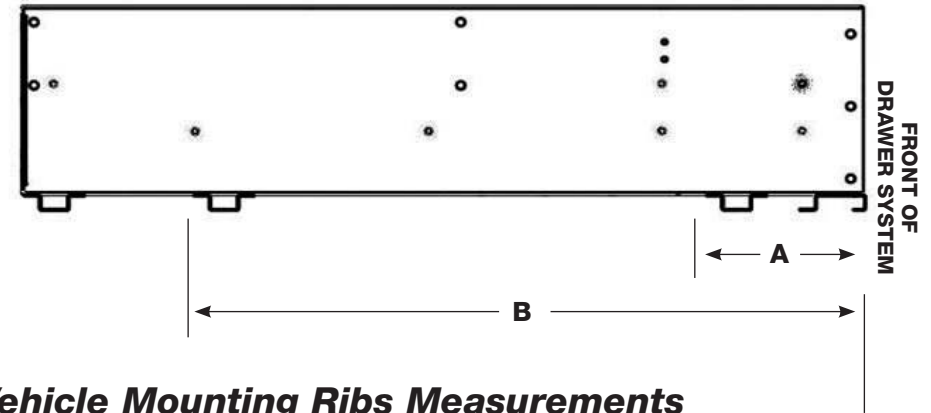

Vehicle Mounting Ribs Measurements

VEHICLE APPLICATION	VEHICLE MODEL	MEASUREMENT "A" (mm)	MEASUREMENT "B" (mm)
Mitsubishi Pajero (NM, NP, NS, NT)	GL, GLX, GLS, VRX, EXCEED (2000 on)	174	640
Landrover Discovery 2 (ES, S, SE, HSE, SE7)	FEB 1999 - 2004	223	BR



Locating & Centralising The Drawer System

1. Prepare the vehicle removing any seats and obstructions. Refer to Page 16 for your vehicle specific instructions.
2. For vehicles with existing mounting points, locate these and align the holes in the floating ribs.
3. For vehicles with no existing mounting points, refer to your vehicle specific instructions.
4. Centralise the Drawer System in your vehicle by taking a reference measurement on the vehicle such as the side panels or wheel arches. Ensure dimensions are equal both sides. This will put the frame where it needs to be and the floating ribs hole positions should now be visible and accurate. This is more critical when you intend to install a wing kit at a later date.
5. Using the measurement provided in the Matrix for LF/RF & RR/RF (on Page 14), locate the existing holes in the floating ribs. In most cases these should line up with existing bolt holes in the floor. Fix the drawer system to your vehicle using these four locations and the prescribed install REF as per Hardware Listing.
6. At this point only tighten bolts to finger tight. Check again for centralising and when correct, tighten down.

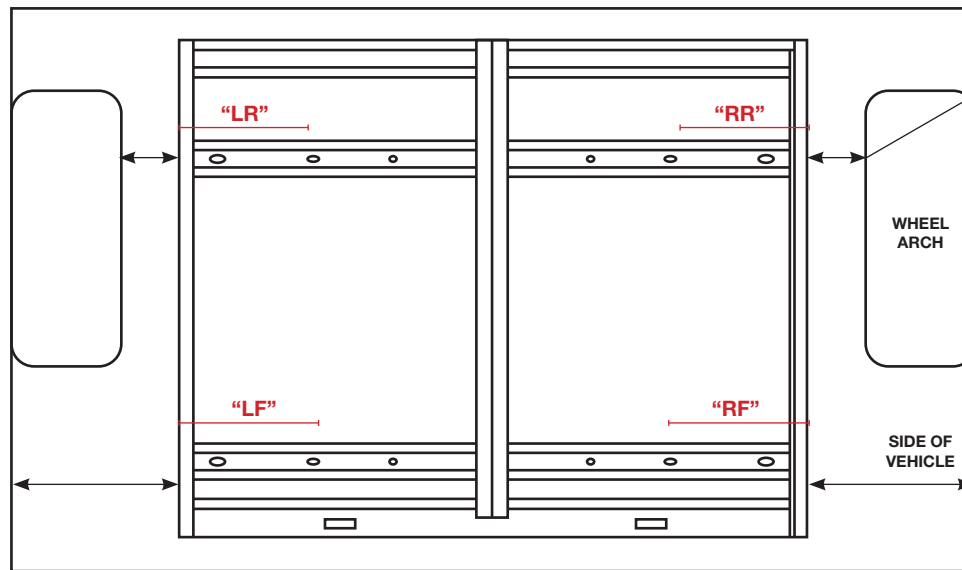

REAR OF VEHICLE

NOTE: To help centralise the unit, use a tape measure to position the frame using the side panels, the wheel arches or a similar reference point on each side.

IMPORTANT: Refer to Matrix for vehicle specific floating rib measurements.



Hardware Location Matrix

MAKE	VEHICLE	MODEL	LF	RF	LR	RR
Mitsubishi	NM, NP, NS, NT Pajero	GL, GLX, GLS, VRX, EXCEED (2000 on)	55	55	285	310
Land Rover	Discovery 2 (Feb 1999 - 04)	ES, S, SE, HSE, SE7	50	50	50	50

Pajero 2 Piece Floating Rib Installation

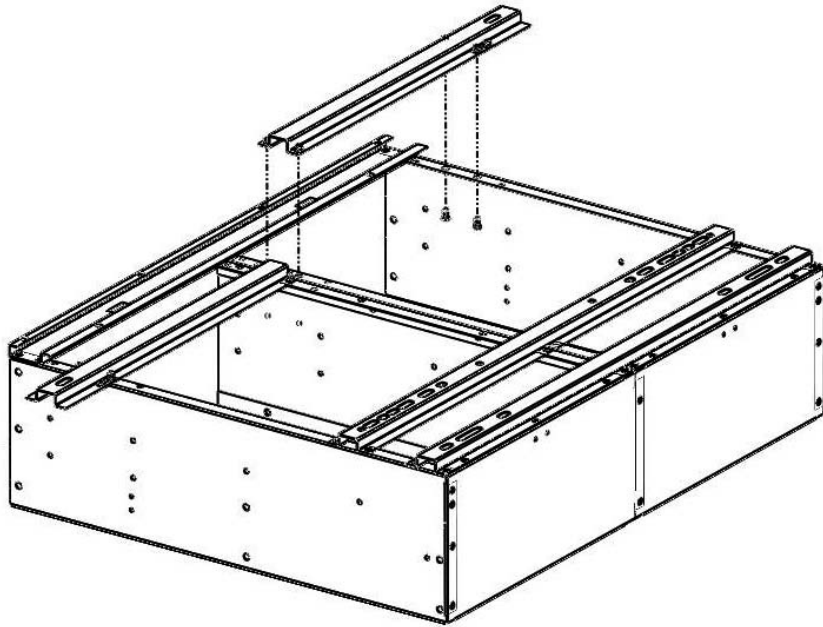

Hardware Listing

VEHICLE APPLICATION	VEHICLE MODEL	HARDWARE USED "LF" (mm)	HARDWARE USED "RF" (mm)	HARDWARE USED "LR (mm)	HARDWARE USED "RR" (mm)
Mitsubishi Pajero (NM, NP, NS, NT)	GL, GLX, GLS, VRX, EXCEED (2000 on)	M10 x 35mm Bolt M10 x 25mm Washer 20mm Packer REF 1	M10 x 35mm Bolt M10 x 25mm Washer 20mm Packer REF 1	M6 x 35mm Bolt M6 x 25mm Washer 20mm Packer REF 1	M6 x 35mm Bolt M6 x 25mm Washer 20mm Packer REF 1
Landrover Discovery 2 (ES, S ,SE, HSE, SE7)	FEB 1999 - 2004	M10 x 35mm Bolt M10 x 25mm Washer 20mm Packer Mudguard Washer M10 Nyloc REF 5	M10 x 35mm Bolt M10 x 25mm Washer 20mm Packer Mudguard Washer M10 Nyloc REF 5	M10 x 35mm Bolt M10 x 25mm Washer 20mm Packer Mudguard Washer M10 Nyloc REF 5	M10 x 35mm Bolt M10 x 25mm Washer 20mm Packer Mudguard Washer M10 Nyloc REF 5

Hardware Application Reference

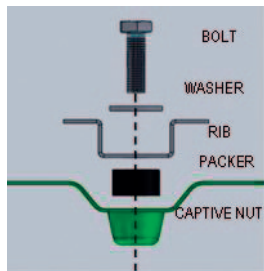

Ref 1

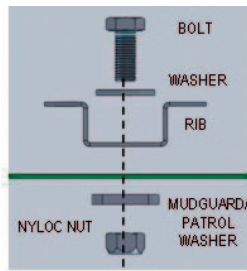

Ref 2

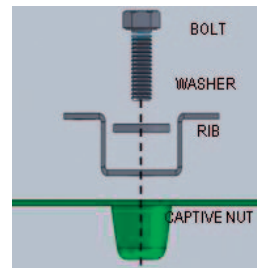

Ref 3

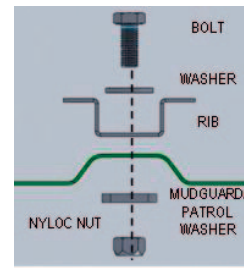

Ref 4

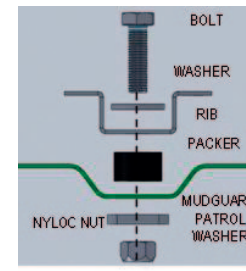

Ref 5



VEHICLE PREPARATION

Mitsubishi Pajero NM-NT



1. Remove rear floor section.



2. Remove rear seats.



3. Remove locking bar for rear seats and refit two inside bolts.



4. Remove tie down points.



5. Place 20mm packer over threaded hole for tie down point.

Landrover Discovery 2

1. Centralise drawer system in cargo area of vehicle.
2. Allow adequate clearance for rear door pocket when door is closed.
3. Refer to Matrix for hole locations.
4. Drill mounting holes to 10.5mm through floor taking care not to damage under floor components eg. Wiring harness, fuel lines, etc.

