

***Rugged  
Ridge*** ®

***Extreme Heavy Duty  
ATV/UTV Recovery Winch***

***2.0 - 2.5***

# **Owners Manual**

## A FEW WORDS ABOUT PRODUCT SAFETY

Your Rugged Ridge® ATV/UTV recovery winch is a powerful tool adding considerable utility and enjoyment to your off road ATV/UTV. Keep in mind, however, that your ATV/UTV's weight, the forces required for ATV/UTV recovery and the variety of terrain, grades and cable rigging you might encounter, result in any winching operation having the potential for serious personal injury or damage to your winch or ATV/UTV. Each winch operation may involve different risks making it impractical to provide warnings or information regarding all the risks you may encounter. Fully understand your Rugged Ridge® instructions and practice safe winch operations before attempting an actual ATV/UTV recovery.

To reduce winch related risks and help you make informed decisions about safety, the accompanying instructions provide certain information in the form of "Warnings", "Cautions" and "Notices". This information alerts you to potential hazards that could hurt you or others.

### NOTICE

This is a caution against anything which may cause damage to your winch, the ATV/UTV or its equipment if the caution is ignored. The Notice includes information about how you can avoid or reduce those risks.



### WARNING

This is a signal telling you that you or others CAN be KILLED or SERIOUSLY HURT if you don't follow the Warning. The Warning includes information about what you must or must not do in order to reduce the risk of injury to yourself and others.



### CAUTION



This is a signal telling you that you or others CAN be HURT if you don't follow the instruction. The Caution includes information about how you can avoid those risks.

### WARNING



#### CABLE ENTANGLEMENT/PINCH/CRUSH HAZARDS

Failure to follow these instructions could lead to severe injury or death. Consult further WARNINGS/CAUTIONS and instructions in this use/installation manual. Due to loads involved, all winching involves significant risks. To minimize risks of injury **Always**:

- Assure winch, mounting, cable and hook are undamaged. ATV/UTV, slope and conditions should not approach maximum rated pull. Leave a safety margin.
- Use supplied hook strap when spooling in or out (no load). Use gloves and keep fingers and body clear of hook, cable and fairlead  
- Position operator away from line of cable. Keep others at a safe right angle from cable and ATV/UTV when winching (min. 1.5 times distance of cable). Use greatest cable length possible while keeping at least five turns around spool.
- Fully engage clutch before powering cable in. Do no disengage or adjust clutch while under load. Pull in stages to avoid heat buildup and motor damage.
- Never use ATV/UTV recovery winch for persons or as hoist. 

# Table of Contents:

Winch Packing List .....	03
Safety Warnings & Precautions .....	04
Winch Assembly & Mounting (2.0 Model) .....	09
Winch Assembly & Mounting (2.5 Model).....	10
• Mount Winch .....	10
• Mount Control Box .....	11
• Mount Connector for Remote .....	12
• Install Wiring .....	12
• Handlebar Switch Assembly .....	13
Check the System .....	14
Winch Maintenance .....	14
Replacing the Rope .....	14
Planning and Use of Your Winch .....	15
Troubleshooting .....	17
Winch Assembly Drawing .....	18
Winch Parts List .....	19
Specifications .....	20
Extreme Heavy Duty 2.0 .....	20
Extreme Heavy Duty 2.5 .....	21

## Winch Packing List

DESCRIPTION	QUANTITY
1. Winch Assembly with Wire Rope .....	1
2. Cap Bolt M8 X 30 .....	2
3. Lock Washers .....	2
4. Flat Washers .....	2
5. M8 Nuts .....	2
6. Mounting Plate .....	1
7. Clevis Hook w/Pin .....	1
8. Power Cord/Switch Assembly .....	1
9. Strap .....	1

# Installing Your Winch

Take a moment to read and understand all instructions and safety information before attempting installation or use of your Rugged Ridge® ATV/UTV recovery winch. Specifications and sample performance (line speed & pull) for your model winch are set out on pages 20-21 herein.

If you have any questions regarding the installation and operation of your ATV/UTV winch, contact Rugged Ridge® Technical Support at 770-614-6101.



## Moving Parts Entanglement Hazard

Failure to observe these instructions could lead to severe injury or death. To avoid injury to hands or fingers:

- **Always** keep hands clear of rope, hook loop, hook and fairlead opening during installation, operation and when spooling in or out.
- **Always** use extreme caution when handling hook and rope during spooling operations.
- **Always** use supplied hook strap whenever spooling rope in or out, during installation, and during operation.
- **Always** keep ATV/UTV in sight during winching operation.
- **Always** wear heavy leather gloves when handling rope.

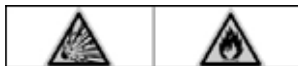

## Chemical and Fire Hazard

Failure to observe these instructions could lead to severe injury or death.

- **Always** remove jewelry and wear eye protection.
- **Never** lean over battery while making connections.
- **Always** verify area is clear of fuel lines, fuel tank, brake lines, electrical wires, etc. when drilling.
- **Never** route electrical cables:
  - » Across any sharp edges.
  - » Through or near moving parts.
  - » Near parts that become hot.
- **Always** insulate and protect all exposed wiring and electrical terminals.



CAUTION

## Moving Parts Entanglement Hazard

Failure to observe these instructions could lead to minor or moderate injury.

- **Always** keep wired remote control lead clear of the drum, rope and rigging. Inspect for cracks, pinches, frayed wires or loose connections. Replace remote control if damaged.
- **Never** leave remote control where it can be activated during freespooling, rigging, or when the winch is not being used
- **Always** require operator and bystanders to be aware of ATV/UTV and or load.



CAUTION

## Moving Parts Entanglement Hazard

Failure to observe these instructions could lead to minor or moderate injury.

### General Safety:

- **Always** know your winch. Take time to fully read the Installation Guide and the Basic Guide to Winching Techniques in order to understand your winch and its operation.
- **Never** operate this winch if you are under 16 years of age.
- **Never** operate this winch when under the influence of drugs, alcohol or medication.
- **Never** exceed winch or rope capacity listed on product data sheet. Double line using a snatch block to reduce winch load

### Installation Safety:

- **Always** choose a mounting location that is sufficiently strong to withstand the maximum pulling capacity of your winch.
- **Always** use factory approved mounting hardware, components, and accessories.
- **Always** use grade 5 (grade 8.8 metric) or better mounting hardware.
- **Never** weld mounting bolts.
- **Always** use care when using longer bolts than those supplied from factory. Bolts that are too long can damage the base and/or prevent the winch from being mounted securely.

- **Always** mount the winch and attach the hook to the rope's end loop before connecting the electrical wiring.
- **Always** spool the rope onto the drum in the direction specified by the winch warning label on the winch and/or documentation. This is required for the automatic brake (if so equipped) to function properly.
- **Always** prestretch wire rope and respool under load before use. Tightly wound wire rope reduces chances of binding, which can damage the rope.



## Moving Parts Entanglement Hazard

Failure to observe these instructions could lead to minor or moderate injury.

- **Always** inspect, rope, hook, and slings before operating winch. Frayed, kinked or damaged rope must be replaced immediately. Damaged components must be replaced before operation. Protect parts from damage.
- **Never** leave remote control plugged into winch when free spooling, rigging, or when the winch is not being used.
- **Never** hook rope back onto itself. This damages the rope.
- **Always** use a choker chain, choker rope, or tree trunk protector on the anchor.
- **Always** remove any element or obstacle that may interfere with safe operation of the winch.
- **Always** take time to use appropriate rigging techniques for a winch pull.
- **Always** be certain the anchor you select will withstand the load and the strap or chain will not slip.
- **Never** engage or disengage clutch if winch is under load, rope is in tension or drum is moving.
- **Always** select an anchor point as far away as possible. This will provide the winch with its greatest pulling power.
- **Never** winch with less than 5 wraps of rope around the drum. The rope could come loose from the drum.
- **Never** touch rope or hook while in tension or under load.
- **Never** touch rope or hook while someone else is at the control switch or during winching operation.
- **Always** stand clear of rope and load and keep others away while winching.
- **Always** be aware of stability of ATV/UTV and load during winching, keep others away.
- **Alert** all bystanders of any unstable condition.
- **Never** use winch to secure a load.



CAUTION



## Moving Parts Entanglement Hazard

Failure to observe these instructions could lead to minor to moderate injury.

- **Always** use a hook with a latch
- **Always** insure hook latch is closed and not supporting load.
- **Never** apply load to hook tip or latch. Apply load only to the center of hook.
- **Never** use a hook whose throat opening has increased, or whose tip is bent or twisted.



WARNING



## Falling or Crushing Hazard

Failure to observe these instructions could lead to severe injury or death.

- **Never** use winch to lift or move persons.
- **Never** use winch as a hoist or to suspend a load.



CAUTION



## Cut and Burn Hazard

Failure to observe these instructions could lead to minor or moderate injury.

To avoid injury to hands and fingers:

- **Always** wear heavy leather gloves when handling a rope.
- **Never** let rope slip through your hands.
- **Always** be aware of possible hot surface at winch motor, drum or rope during or after winch use.

## NOTICE

### **Avoid Winch and Equipment Damage**

- **Always** avoid side pulls which can pile up rope at one end of the drum. This can damage rope or winch.
- **Always** ensure the clutch is fully engaged or disengaged.
- **Never** use winch to tow other vehicles or objects. Shock loads can momentarily exceed capacity of rope and winch.
- **Always** avoid “powering out” for extended distances. This causes excess heat and wear on the winch motor and brake.
- **Always** use care to not damage the ATV/UTV frame when anchoring to a vehicle during a winching operation.
- **Never** “jog” rope under load. Shock loads can momentarily exceed capacity of rope and winch.
- **Never** use winch to secure a load during transport.
- **Never** submerge winch in water.
- **Always** store the remote control in a protected, clean, dry area.
- **Always** double line or pick distant anchor point when rigging. This maximizes pulling power and avoids overloading the winch.



## CAUTION

To prevent accidental activation of the winch and serious injury, complete the winch installation and attach the hook before installing the wiring.



# Winch Assembly and Mounting for 2.0 Model

## Step 1 - Mount the Winch

Consult your ATV/UTV manufacturers owner's manual for all specific winch related recommendations, instructions and warnings before installation.

To secure the winch, always use:

- A flat, secure mounting location at least 4.8 mm (3/16 in.) Thick.
- Lock washers.
- Hex head cap screws when using a one-piece winch mount plate.

**Note:** When using separate winch mount and fairlead plates use hex head cap screws on the motor side of the base as shown in Figure 2.

- Torque the mounting bolts to 16 N-m (12 lb-ft)
- Attach the clevis hook to the wire rope.
  - » Put clutch in freespool position.
  - » Manually feed cable loop through fairlead.
  - » Attach hook to cable loop and re-engage clutch.

## Step 2 - Mount the Control Box



Batteries contain gases which are flammable and explosive. Wear eye protection during installation and remove all jewelry. Do not lean over battery while making connections.

To install the control box:

- Mount the control box on winch.
- Connect the short red cable to the "+" terminal of the motor.
- Connect the short black cable to the "-" terminal of the motor.
- Connect the long red cable to the "+" terminal of the battery.
- Connect the long black cable to the "-" terminal of the battery.

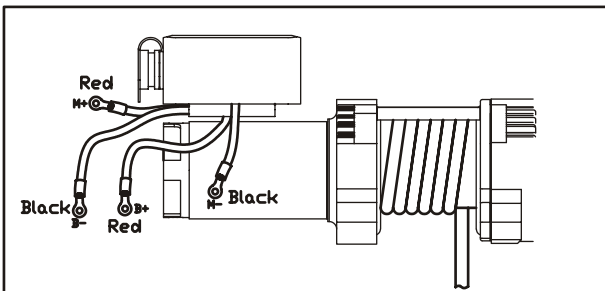

## Winch Assembly and Mounting for 2.5 Model

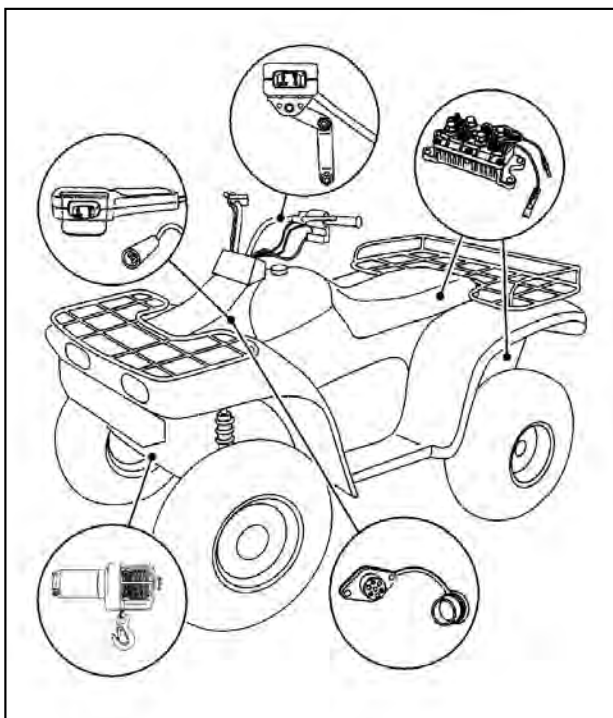

Figure 1: To install the complete kit, you will need to mount the winch, control box, handlebar mounted Mini-rocker switch and remote socket.

### Step 1 - Mount the Winch

Consult your ATV/UTV manufacturer's owner's manual for all specific winch related recommendations, instructions and warnings before installation.

To secure the winch, always use:

- A flat, secure mounting location at least 4.8 mm (3/16 in.) thick.
- Lock washers.
- Hex head cap screws when using a one-piece winch mount plate.

**Note:** When using separate winch mount and fairlead plates use hex head cap screws on the motor side of the base as shown in Figure 2 (See Page 12).

- Torque the mounting bolts to 16 N-m (12 lb-ft)
- Attach the clevis hook to the wire rope.
  - » Put clutch in freespool position.
  - » Manually feed cable loop through fairlead.
  - » Attach hook to cable loop and re-engage clutch.

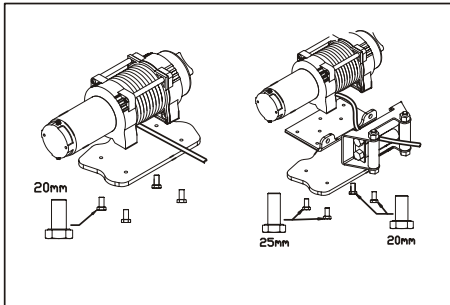
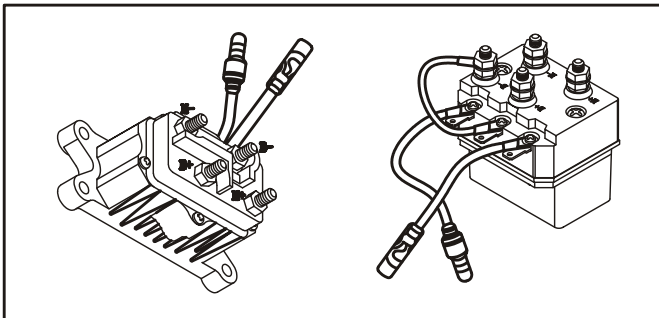

Figure 2: Orientation of winch to mounting plate and bolt lengths

## Step 2 - Mount the Control Box

The control box is a primary safety feature in your winch system. It disconnects your winch from its power source when the ATV is not in use. The control box must be correctly installed to work properly. It is recommended that the control box be mounted close to the battery and in a location that is as clean and dry as possible. Exact location will vary, depending on the ATV. Usual locations include inside, on top, or on the side of rear storage box, and on a few models, under the seat.

Ensure the control box mounting location selected provides sufficient clearance from all metal structures such as frame tubes. Do NOT place tools or other items in a position that might come in contact with the control box directly. Drill the mounting holes for the control box at this time, then move on to step four as it will be easier to attach all the wiring to the control box before attaching it to the ATV. Do NOT mount the control box at this time.



## Step 3 - Mount the Connector for Remote

### **⚠ WARNING**

#### **TO PREVENT SERIOUS INJURY OR DEATH FROM EXPLOSION:**

- Do NOT drill into gas tank.
- Verify the area is clear behind the mounting location before drilling.
- After determining the mounting location for the remote socket, drill three holes and install. (see figure 3)
- Once the remote socket is mounted, route the two bullet terminal wires back to where the control box will be mounted. Splice the end of the red wire to a key controlled accessory circuit of the ATV (use the provided wire splice). Using a test light, locate a suitable wire from the ATV key switch. The wire should only have power when the key is in the “ON” position.
- **NOTE: If installing both switches, both red wires MUST be spliced to a key controlled accessory circuit of the ATV as described above.**

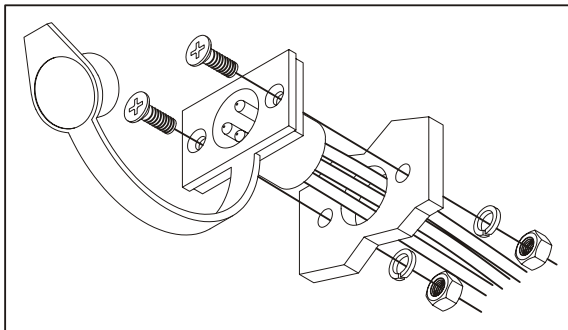

Figure 3: Remote socket installation

## Step 4 - Install the Wiring

### **⚠ CAUTION**

Place the supplied terminal boots on wires before securing to the control box. All wires must be attached to the control box before mounting the control box to the ATV.

- Connect one terminal (marked “M+”) of control box to terminal positive (+) of the motor with red cable.
- Connect one terminal (marked “M-”) of control box to terminal negative (-) of the motor with black cable.
- Connect one terminal (marked “B+”) of control box to terminal positive (+) of the motor with red cable.
- Connect one terminal (marked “B-”) of control box to terminal negative (-) of the motor with black cable.
- If installing both the handle bar switch and the remote socket, first attach the terminals on the green and black remote socket wires into the control box (green to green, black to black), second connect the red cable of remote socket to the terminal (marked “B+”) of the control box, or connect the red cable of remote socket to the key.

## Step 5 - Handlebar Switch Assembly

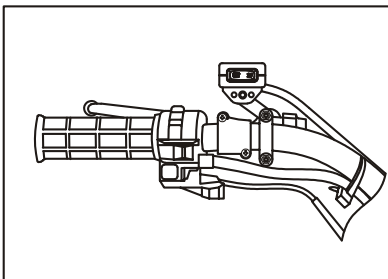

Handlebar mount assembly. Exact positioning may vary depending on ATV make and model.

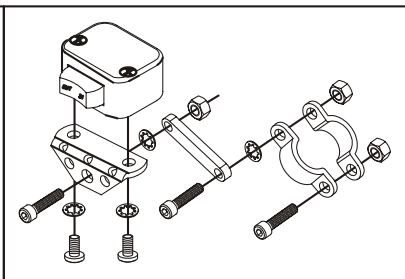

Mini-rocker switch

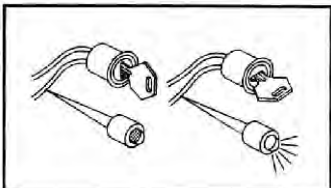

Use a test light to locate a suitable wire.

It is recommended that the switch be installed on the left handlebar. A piece of electrical tape around the handlebar will help prevent rotation of mount on the handle bar. Do not tighten over any hoses or cables. Once the handle bar switch is mounted, route the two bullet terminal wires back to where the control box will be mounted. Splice the end of the red 20ga wire to key controlled electrical wire of the ATV. Using a test light, locate a suitable wire from the ATV key switch. The wire should only have power when the key is in the "ON" position.

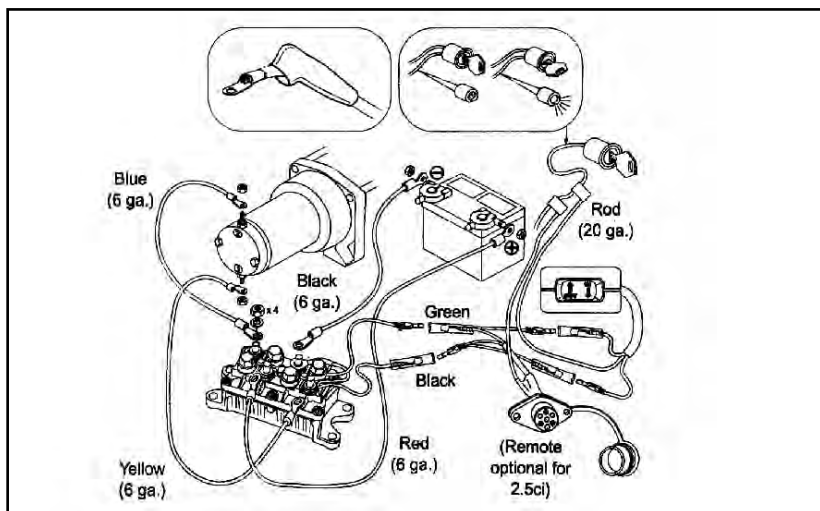

## Check the System

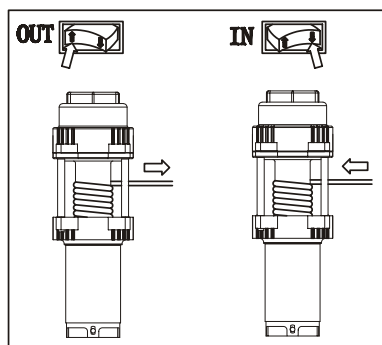

Before using the winch, verify the following:

Wiring to all components is correct. All loose wires are tie wrapped tight. There are no exposed wiring or terminals. Cover any existing terminal exposures with terminal boots, heat shrink tubing or electricians tape. Turn ATV key switch to ON position. Check winch for proper operation. The wire rope should spool in and out in the direction indicated on the switch.

## Winch Maintenance:

- No further internal lubrication is required for the life of the winch. The winch should not be immersed in water. If the winch is immersed in water by accident, you should dry out all components and run until motor is warm.
- Clean winch after each use; Also store the winch in a dry place, disengage the clutch , and avoid access to children.
- Replace or repair any components that become corroded or damaged.

## Replacing Wire Rope:

- If the wire rope has become worn or is beginning to show signs of strands breaking it must be replaced before being used again. To do this, remove the defective rope by free spooling. Remove the M5x5mm bolt on the drum and release the rope.
- Insert the end of new rope and secure the M5x5mm bolt tightly
- Engage the clutch and re-spool the new rope on the drum keeping tension on the rope as it spools. Ensure that the rope is respooling in the under wind position.

**⚠ WARNING** Only replace the wire rope with the identical replacement part recommended by the manufacturer.

# Planning and Use of Your Winch

**⚠ WARNING** Read and understand all instructions and related **Warnings, Cautions & Notices** before attempting to install or use your Rugged Ridge® winch.

**1.** Ensure ATV/UTV, slope and conditions do not approach maximum rated pull. Leave a safety margin. Winch provides greater mechanical advantage when cable is fully extended. Plan pull using as much cable as practical. Double line using snatch block is preferred.

**⚠ WARNING** **Secure cable attachment requires at least five (5) wraps on Spool. Do not extend red painted cable. Secure synthetic rope attachment requires a full layer on the spool. DO NOT EXCEED RATED PULL LESS SAFETY MARGIN.**

**2.** Plan and center anchor and snatch blocks or rigging so cable pulls straight to winch. Confirm anchor point will support load with adequate safety margin. Where anchor is tree use trunk protector and shackle rated at least double maximum winch pull. Where anchor is vehicle, (see below) fully engage cable hook through towing eye or shackle rated at least double maximum winch pull. Attach to vehicle frame **not** bumper or winch mount.

**⚠ WARNING** ATV/UTV to Vehicle winching not recommended as it may exceed capacity of winch, mounting or cable. Do not drive vehicle while winching. Avoid slack cable or shock loads to reduce risk of failure. Maintain steady tension through winch and block vehicle at safe intervals. Winch not intended to tow vehicles or secure loads. Never use recovery strap as part of winch operation. Stretch/stored energy in recovery strap may create shock load.

**3.** Extend cable manually by disengaging clutch to free spool. Confirm cable hook fully engages anchor, strap or shackle. Do not fix hook back around cable to avoid damage. Confirm power switch on Control Handle is "OFF" and attach remote. Fully engage clutch before powering spool. Keep vehicle motor running to avoid battery drain.



- **Always keep hands, body and clothing clear of cable, hook and fairlead during operation and spooling.**
- Reduce risk of cable-related injury by clearing persons and establishing safe zone equal to at least 1.5 times length of cable. Keep operator away from cable and line of pull. Operator should be at right angle to cable and protected by vehicle where possible. Confirm anyone assisting understands recovery plan and safety precautions.
- **Always wear gloves and use supplied hook strap when handling cable; never touch cable under tension. Never work under or over cable under tension. Use Rugged Ridge® dampener or substitute (heavy blanket) over cable mid-point to dampen energy in event cable fails. Slack cable before moving blanket or dampener.**

**4.** Plan your pull, recognizing recovery winches are not intended for continuous duty. Heavy load and slow line speed indicate high amperage draw causing heat build-up in motor. **▲ NOTICE** Avoid damaging motor by adjusting to shorter pull cycles and longer cool-down periods under heavy load. Do not continue power to stalling motor.

**5.** Begin pull by gradually taking tension on cable to avoid shock loads. As you power in, cable must wind tightly and evenly on drum to prevent over-wraps and cable damage. Avoid side-pull on spool or cable stacking against spool side plates.

**▲ WARNING**

**CABLE ENTANGLEMENT HAZARD**

**Cable must rewind in direction of arrow indicated on spool housing for spool brake to function. If cable stacks or does not spool properly, block or secure vehicle and slowly power-out problem section. Keeping gloved hands clear of fairlead and spool, reposition cable to opposite side of spool. Stand clear of winch while gradually regaining tension on cable.**

**6.** Complete pull by securing ATV/UTV in gear with parking brake on. Slowly power cable out to remove tension before securing rigging.

**▲ NOTICE** **Cable must be stored evenly and tightly on spool to prevent damage.** Using gloves, grasp cable in sections at least 6 feet (2 meters) from fairlead. Slowly power cable onto spool while maintaining light tension to produce tight, even wraps.



**▲ WARNING**



- **Always keep hands, body and clothing clear of cable, hook and fairlead during operation and spooling.**
- **Wire spurs and strands from cable can cause serious injury. Always use gloves and do not allow cable to slip through hands. Maintain at least 6 feet (2 meters) between your position with cable and fairlead. For control and safety, keep power switch with person holding cable strap.**
- **Always use hook strap when hook is within 6 feet (2 meters) of fairlead. Secure hook to vehicle frame or tow eye and slowly power spool to complete storing cable under light tension. Remove and secure power switch.**



# Troubleshooting

NO.	SYMPTOM	POSSIBLE	SUGGESTED
1	Motor does not turn on	<ul style="list-style-type: none"> <li>• Switch Assembly not connected properly</li> <li>• Loose battery cable Connections</li> <li>• Solenoid malfunctioning</li> <li>• Defective Switch Assembly</li> <li>• Defective motor</li> <li>• Water has entered motor</li> </ul>	<ul style="list-style-type: none"> <li>• Insert Switch Assembly all the way into the connector.</li> <li>• Tighten nuts on all cable connections.</li> <li>• Tap solenoid to loosen contacts. Apply 12volts to coil terminals directly A clicking indicates proper activation.</li> <li>• Replace Switch Assembly</li> <li>• Check for voltage at armature port with Switch pressed. If voltage is present replace motor.</li> <li>• Allow to drain and dry. Run in short bursts without load until completely dry.</li> </ul>
2	Motor runs but Cable drum does not turn	<ul style="list-style-type: none"> <li>• Cam Ring (clutch) not engage</li> </ul>	<ul style="list-style-type: none"> <li>• Move Cam Ring to the in position. If problem persists, a qualified technician needs to check and repair.</li> </ul>
3	Motor runs slowly or without normal power	<ul style="list-style-type: none"> <li>• Insufficient current or voltage</li> </ul>	<ul style="list-style-type: none"> <li>• Battery weak, recharge. Run winch with ATV/UTV motor running.</li> <li>• Loose or corroded battery cable connections. Clean, tighten, or replace</li> </ul>
4	Motor runs too hot	<ul style="list-style-type: none"> <li>• Long period of operation</li> </ul>	<ul style="list-style-type: none"> <li>• Let winch cool down periodically</li> </ul>
5	Winch runs in one direction only	<ul style="list-style-type: none"> <li>• Defective or stuck solenoid</li> <li>• Defective Switch Assembly</li> </ul>	<ul style="list-style-type: none"> <li>• Tap solenoid to loosen contacts.</li> <li>• Repair or replace solenoid.</li> <li>• Replace Switch Assembly</li> </ul>

# Winch Assembly Drawing

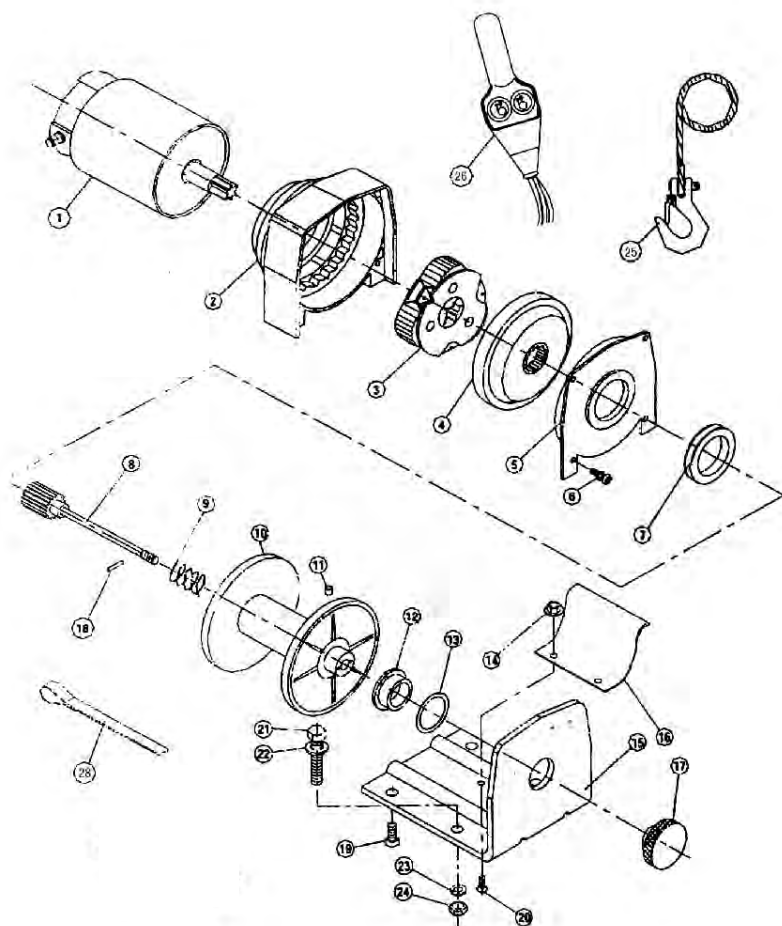

# Winch Parts List

No.	QTY	Description
1	1	Motor
2	1	Stationary Gear Housing Assembly
3	1	Gear Carrier Assembly
4	1	T-Series Rotator Gear
5	1	Drum Support Plate
6	4	Spring Washer 4 & Pan Head Screw M4 X 12
7	1	Drum Support Bushing
8	1	Clutch Assembly
9	1	Spring
10	1	Drum Assembly
11	1	Screw M5 X 5
12	1	T-Series Bushing
13	1-2	Thick Flat Washer
14	2	Hex Flange Nut M5
15	1	T-Series Base Plate Assembly
16	1	Tension Plate
17	1	T-Series F/W Knob Assembly
18	1	Elastic Pin 2.5 X 14
19	1	Cap Screw M6 X 16
20	2	Screw M5 X 10
21	2	Screw M8 X 30
22	2	Flat Washer 8
23	2	Lock Washer 8
24	2	Nut M8
25	1	Cable Assembly
26	1	Switch Assembly
28	1	Strap

# Specifications

## *Extreme Heavy Duty 2.0*

### Specifications

Rated line pull: 2000lbs (907kgs) single line

Motor: Permanent magnetic DC 12V with  
(1.1hp)/0.82kw output

Gear Train: Differential planetary

Gear Ratio: 153 : 1

Wire Rope: 4mm x 15.2m (5/32"x50')

Drum Size: 31.5mm x 72mm

Dimensions: 285mm x 105mm x 105mm

N.W: 6.5 kg (14.3 lbs)

G.W: 9.5 kg

### Line speed and motor current (first layer)

Line Pull	LBS	0	500	1000	1500	2000
	KGS	0	227	454	680	907
Line Speed	FPM	10.5	9.2	7.5	5.2	2.9
	MPM	3.2	2.8	2.3	1.6	0.9
Motor Current	Amps	12	30	60	75	90

### Line pull and cable capacity

Layer of cable		1	2	3	4	5	6
Rated line pull Per layer	LBS	2000	1630	1380	1190	1050	940
	KGS	906	740	620	540	470	420
Cable capacity Per layer	Ft.	6.5	14	23.5	35	47	50
	M	2.0	4.3	7.2	10.6	14.4	15.2

# ***Extreme Heavy Duty 2.5***

## **Specifications**

Rated line pull: 2500lbs (1134kgs) single line

Motor: Permanent magnetic DC 12V with  
(1.1hp)/0.82kw output

Gear Train: Differential planetary

Gear Ratio: 153 : 1

Wire Rope: 4.8mm x 15.2m (3/16"x50')

Drum Size: 31.75mm x 72mm

Dimensions: 300mm x 105mm x 105mm

N.W: 7 kg (15.4 lbs)

G.W: 10.5 kg

## **Line speed and motor current (first layer)**

Line Pull	LBS	0	1000	2000	2500
	KGS	0	454	907	1134
Line Speed	FPM	10	7.1	3.3	2.6
	MPM	3.0	2.15	1.3	0.8
Motor Current	Amps	12	60	90	120

## **Line pull and cable capacity**

Layer of cable		1	2	3	4	5
Rated line pull Per layer	LBS	2500	2000	1800	1590	1380
	KGS	1134	907	816	720	620
Cable capacity Per layer	Ft.	4.9	11.5	19.3	28.5	32
	M	1.5	3.5	5.9	8.7	10